

MSL MAINS LOCK SWITCHES

GENERAL ELECTRICAL & MECHANICAL SPECIFICATION

Switch Rating:	4/80A @ 250Vac R/C
Life:	>15,000 Cycles
Operating Temperature:	-25°C to +85 °C
Proof Voltage:	3kV min. (Initial)
Insulation Resistance:	>999 MΩ at 500Vdc (Initial)
Contact Resistance:	<20 mΩ (Initial)
Switch contacts:	Silver Cadmium Oxide
Switch Chamber:	Polyamide 6.6 G.F. V0 Rated
Tag Panel:	SRBP
Terminals:	Brass CZ108 Ag Plated
Lock Housing:	Zinc Alloy Bright Cr Plated
Keys:	Mild Steel Ni Plated

RoHS COMPLIANT



SWITCH MODULE IS ENEC APPROVED TO EN61058 BY VDE.

Note: CHANGEOVER TYPE HAS NO APPROVALS.

GENERAL FEATURES

- Made in UK.
- Two part construction. The lock is inserted into the panel from the front. The mains switch module either bracketed or snap-on, from the rear of the panel.
- Standard solder terminals (Printed circuit terminals optional – add /P to part number).
- Two keys per lock. Additional keys to order.
- Keys to pass (same key all locks) or differ (different key per lock).

CIRCUITRY	TERMINAL LAYOUT VIEWED FROM REAR OF SWITCH	KEY WITHDRAWAL POSITIONS
2 POLE OFF-ON		
2 POLE 1 OFF 1 ON		
2 POLE ON-OFF (NORMALLY CLOSED)		
2 POLE CHANGEOVER (No approvals)		
NOTE: By externally linking the two pole terminals a 1 pole c/o is made		

MOUNTING DETAILS FOR BRACKETED MSL, MIS LOCKSWITCHES

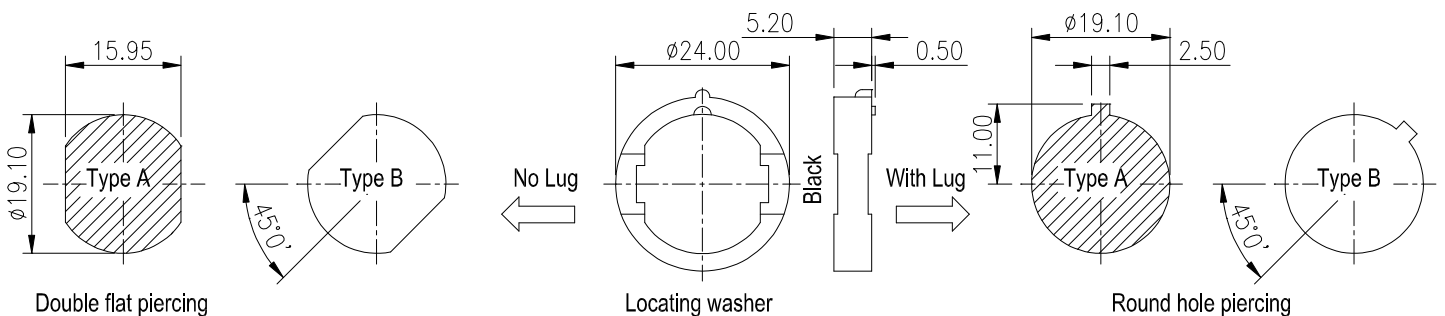

MSL MAINS LOCK SWITCHES

MSL

LOCKSWITCH WITH BRACKETED MS MODULE

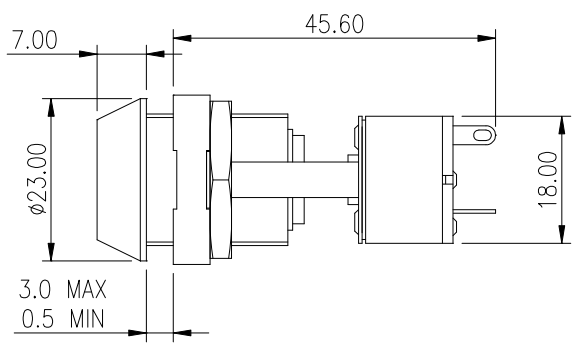

STANDARD MSL SWITCHES & PART NUMBERS				
2 POLE OFF-ON	2 POLE 1-OFF 1-ON	2 POLE CHANGEOVER	KEY NUMBERS	POSITION IN WHICH KEY FREE
MSL 8601B	MSL 8603B	MSL 8605B	Differs	0° and 90° (1+4)
MSL 8602B	MSL 8604B	MSL 8606B	Same	0° and 90° (1+4)
MSL 8609A	MSL 8611A	MSL 8613A	Differs	0° only (1)
MSL 8610A	MSL 8612A	MSL 8614A	Same	0° only (1)

LOCK TYPE: 8 Disc with built-in anti-pick system.
LOCK MOVEMENT: 90° Steps.
LOCK COMBINATIONS: 2000 differs or all to pass (same key for all locks).
KEY TYPE: Flat, double entry (key can be inserted into the lock either way up).
MASTER KEY SYSTEM AVAILABLE: Yes.
MAXIMUM PANEL THICKNESS: 3mm.
MODULE TYPE: Bracketed (the switch module is fitted to a "U" shaped bracket).

MSL5

LOCKSWITCH WITH SNAP-ON MS MODULE

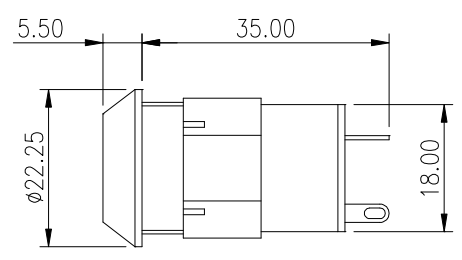

STANDARD MSL5 SWITCHES & PART NUMBERS				
2 POLE OFF-ON	2 POLE 1-OFF 1-ON	2 POLE CHANGEOVER	KEY NUMBERS	POSITION IN WHICH KEY FREE
MSL 8621	MSL 8625	MSL 8629	Differs	0° and 90° (1+4)
MSL 8622	MSL 8626	MSL 8630	Same	0° and 90° (1+4)
MSL 8623	MSL 8627	MSL 8631	Differs	0° only (1)
MSL 8624	MSL 8628	MSL 8632	Same	0° only (1)

LOCK TYPE: 5 Disc.
LOCK MOVEMENT: 90° Steps.
LOCK COMBINATIONS: 200 differs or all to pass (same key for all locks).
KEY TYPE: Flat, double entry (key can be inserted into the lock either way up).
MASTER KEY SYSTEM AVAILABLE: Yes.
MAXIMUM PANEL THICKNESS: 3.4mm.
MODULE TYPE: Snap-on

MIS(Impulsion)

LOCKSWITCH WITH BRACKETED MS MODULE

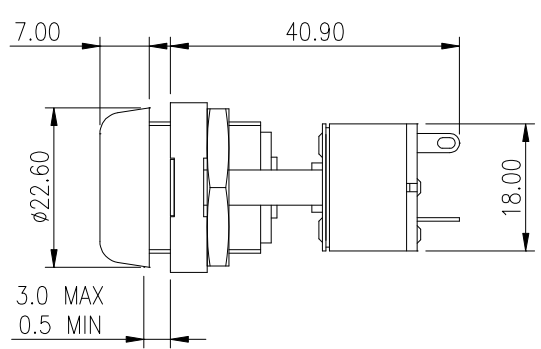

STANDARD MIS SWITCHES & PART NUMBERS				
2 POLE OFF-ON	2 POLE 1-OFF 1-ON	2 POLE CHANGEOVER	KEY NUMBERS	POSITION IN WHICH KEY FREE
MIS 8659	MIS 8661	MIS 8663	Differs	0° only (1)
MIS 8660	MIS 8662	MIS 8664	Same	0° only (1)

LOCK TYPE: 3 Disc impulsion lock (spring back to position 1)
LOCK MOVEMENT: 90° Steps.
LOCK COMBINATIONS: 2000 differs or all to pass (same key for all locks).
KEY TYPE: Flat, double entry (key can be inserted into the lock either way up).
MASTER KEY SYSTEM AVAILABLE: Yes.
MAXIMUM PANEL THICKNESS: 3mm.
MODULE TYPE: Non-Approved - Bracketed (the switch module is fitted to a "U" shaped bracket).