

MS 2000 SIGNAL ROTARY SWITCH

GENERAL ELECTRICAL & MECHANICAL SPECIFICATION

RoHS COMPLIANT

Switch Rating:	20mA @ 24V DC
Life:	50,000 Cycles
Operating Temp:	-25°C to +85°C
Proof Voltage:	2.5KV (Initial)
Insulation Resistance:	>999 MΩ @ 500V DC (Initial)
Contact Resistance:	<20 mΩ (Initial)
Contact Gap:	3mm
Switch Contacts:	Ag CdO + Au plated
Switch Chamber:	Polyamide 6.6 G.F. V0 Rated
Tag Panel:	SRBP
Terminals:	Brass CZ108 Ag Plated

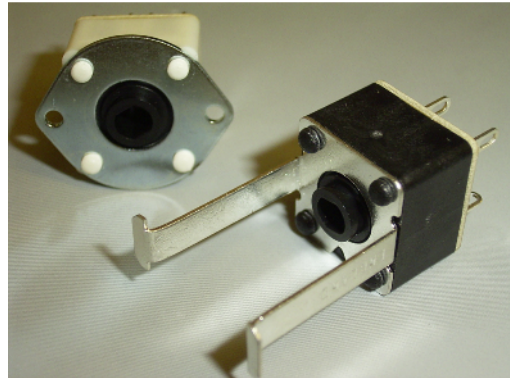

2 POLE OFF- ON (NORMALLY OPEN)		
	PLATE	BRACKET
ORDERING CODE	MS2215 90° SOL	MS2211 90° SOL

2 POLE CHANGEOVER		
	PLATE	BRACKET
ORDERING CODE	MS2214 90° SOL	MS2212 90° SOL

STANDARD SWITCH DETAIL

MOUNTING BRACKET

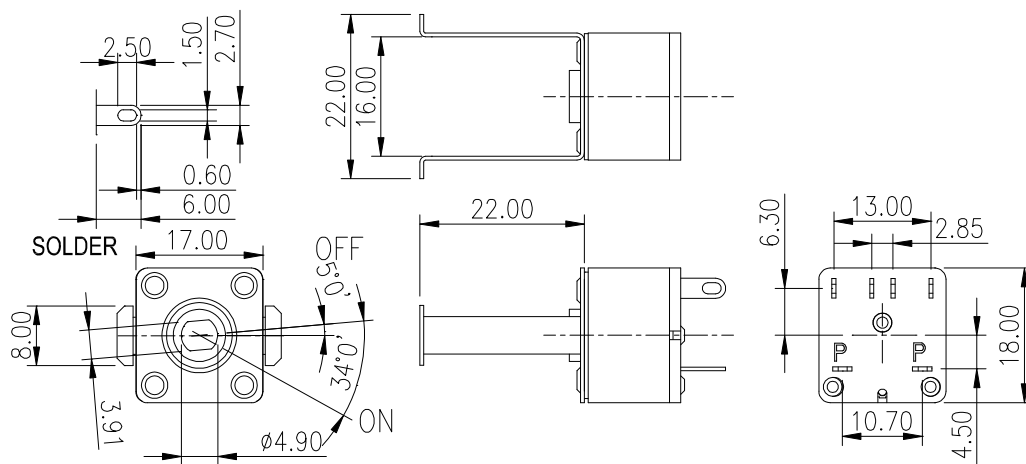

Orientation in OFF-Position
ie Fully anti-Clockwise

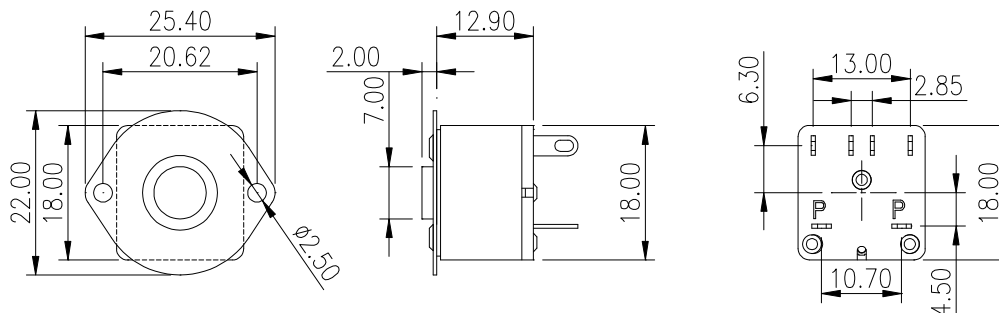

MOUNTING PLATE